



 **PESATRICE ELETTRONICA mod. G09-126**

Pesatrice automatica ed elettronica per prodotti ortofruitticoli composta da : - Elevatore a nastro a tacche con tramoggia di deposito prodotto. - Sistema distribuzione prodotto a piattaforme vibranti. - Alimentazione/trasporto prodotto, per mezzo di 9 canali vibranti.- N° 9 Tramogge contenimento prodotto, pesatura a celle di carico con palette di scarico a doppia apertura . - Nastro evacuazione dosi per l'alimentazione confezionatrice a valle. - Quadro elettronico per il funzionamento automatico, completo di Touch-screen impostazione e visualizzazioni programmi e parametri di lavoro (peso, tolleranza, ecc.).

Peso delle confezioni: da 0,5 a 25 kg.

--**OPTIONAL:** a) TRAMOGGIA PNEUMATICA di scarico per accoppiamento con confezionatrici . b) NASTRI DI SCARICO SDOPPIATI per scaricare contemporaneamente su tre confezionatrici.

 **ELECTRONIC WEIGHING MACHINE mod. G09-126.**

- Cleated belt elevator carrying the produce from the storage hopper to the in-feed. (not included in the machine but ordered separately) - Conveyance of fruit with vibrating plates. - In-feed system by 9 vibrating channels.- Weighing system by 9 weighing hoppers, with double opening flap.- Belt conveyor to transfer the weighed produce to the packaging machine, if necessary in down-going position. - Electronic panel for the automatic functions, complete with touch-screen and keyboard to enter the working parameters (weight, tolerance, etc.) Each pack: from 0,5 to 25 kg.OPTIONAL:PNEUMATIC HOPPER for coupling with packaging machine.DOUBLED OUTLET CONVEYORS to allow lateral and/or central discharge.

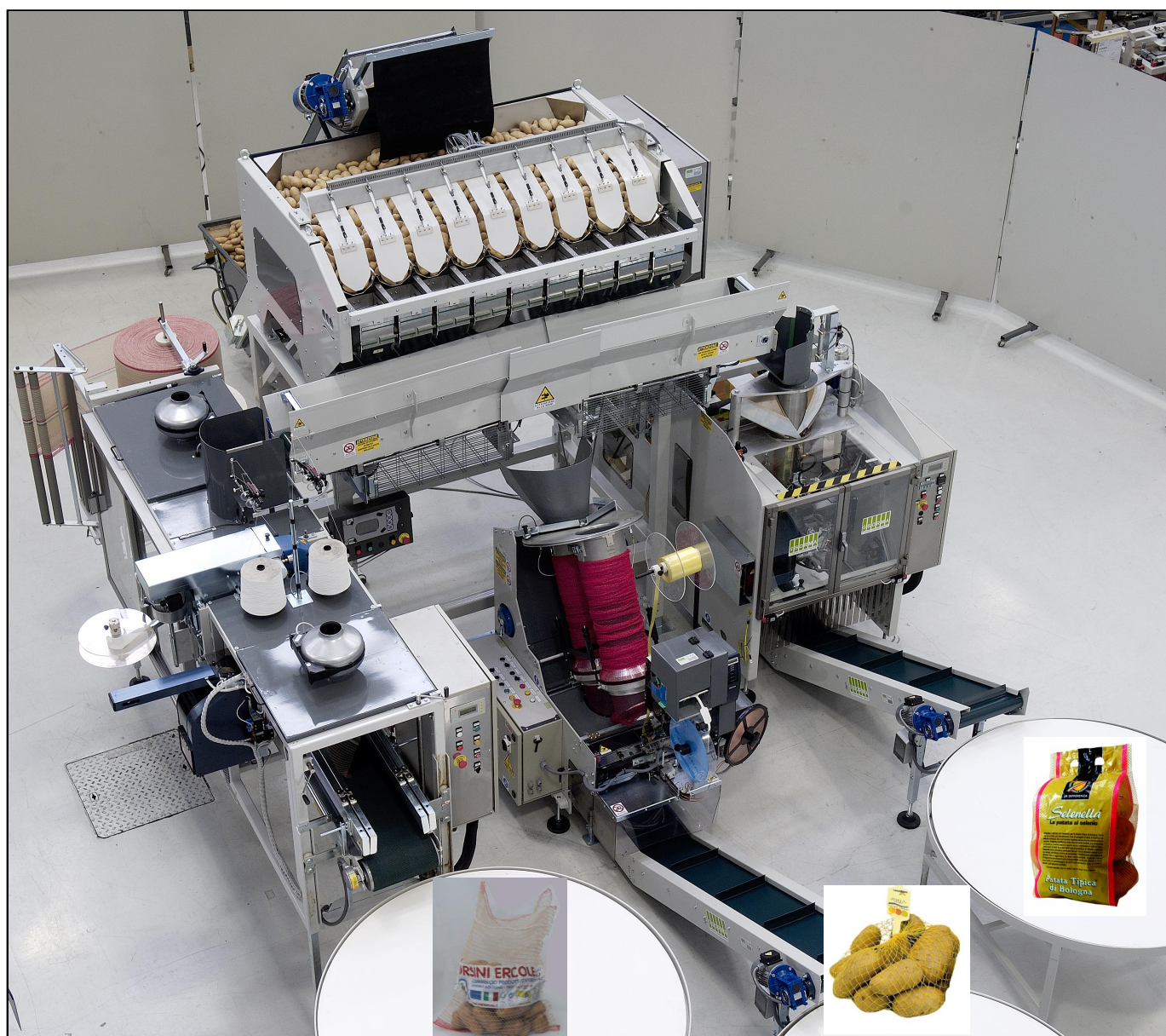

**TECNICAL - DATA : G09-126**

PRODUZIONE PESATRICE : DÉBIT PESEUSE : OUTPUT WEIGHING : LEISTUNG WIEGEMASCHINE : PRODUCCIÓN PESADORA :	1 kg. up to 27 pack/min 2,5 kg. up to 27 pack/min 5 kg. up to 20 - 23 pack/min 10 kg. up to 16 - 18 pack/min 25 kg. up to 6 - 8 pack/min
POTENZA ELETTRICA INSTALLATA PUISSANCE ÉLECTRIQUE INSTALLÉE INSTALLED POWER INSTALLIERTE ELEKTRISCHE LEISTUNG POTENCIA ELECTRICA INSTALADA	<b>3.5 KW 50 HZ</b> <b>400 V 3PH</b>
CONSUMO ARIA CONSUMMATION D'AIR AIR CONSUPTION LUFTVERBRAUCH CONSUMO DE AIRE	<b>60 NLt/min</b>

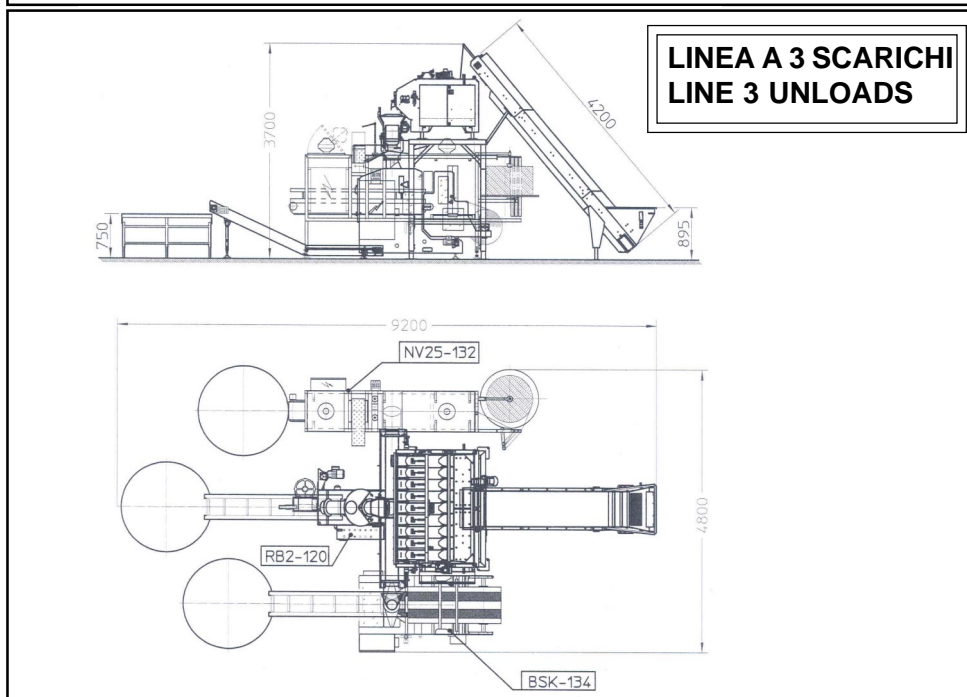
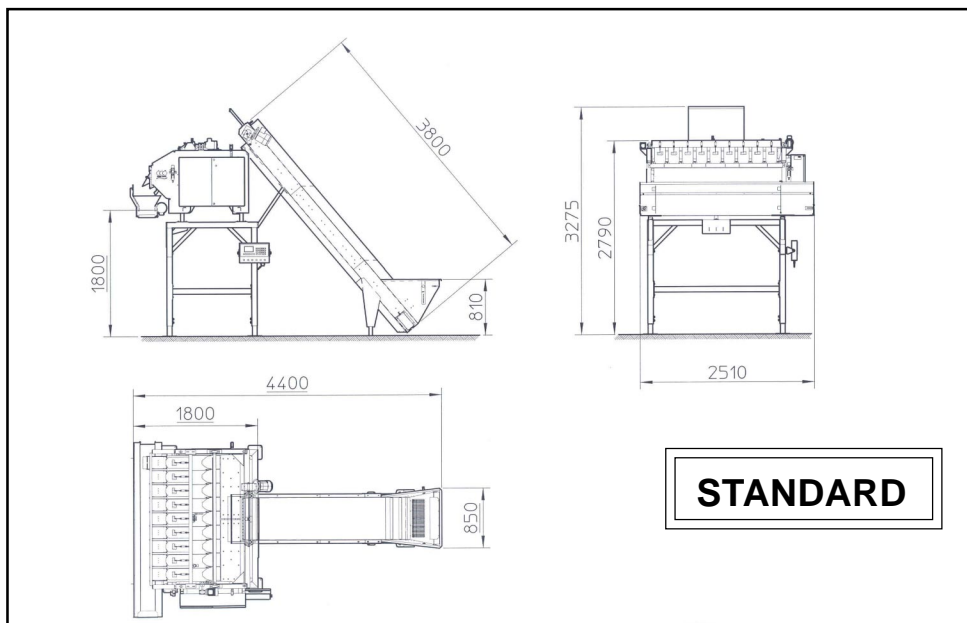
**SORMA S.p.A.**

via Delle Mele nr. 65

47020 CESENA ITALY

Tel.: 0547-418611 - Fax 0547- 418628

e-mail: sorma@sormaitalia.com

